

LITTLE FWEND

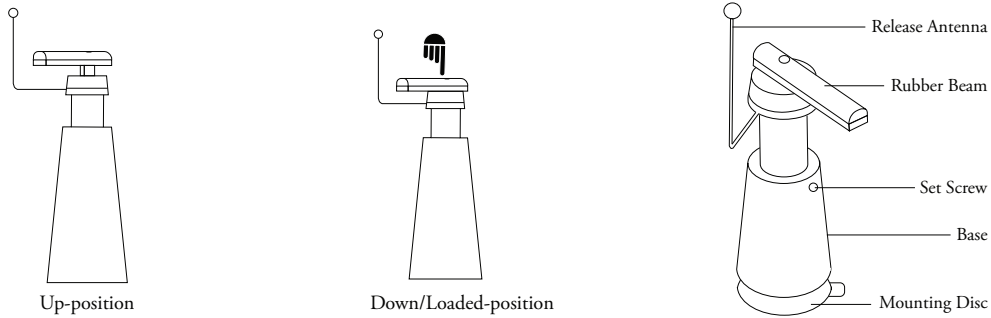

MOUNTING INSTRUCTIONS. READ THROUGH BEFORE INSTALLING. THE RELEASE ANTENNA IS VERY SENSITIVE, THINK OF IT AS THE CANTILEVER IN A CARTRIDGE. THE FINE MECHANICS INSIDE MIGHT NOT FUNCTION PROPERLY IF THE ANTENNA IS BENT OUT OF SHAPE. THE TURNTABLE MOTOR SHOULD BE POWERED OFF UNTIL MOUNTING IS COMPLETED.



SET HEIGHT

Height is adjusted by a set screw in the base using the enclosed allen key.

A. Leave the tonearm in its resting position.

B. Put a 12" vinyl record on the platter.

C. Place Little Fwend on a flat surface between the base of the tonearm and the platters edge.

D. Lower the stylus down to the records surface. Precise positioning of the stylus or Little Fwend is not important at this point.

E. Gently push the rubber beam down to its loaded position. Adjust the height so there is a 1mm clearance between the tonearm and the rubber beam.

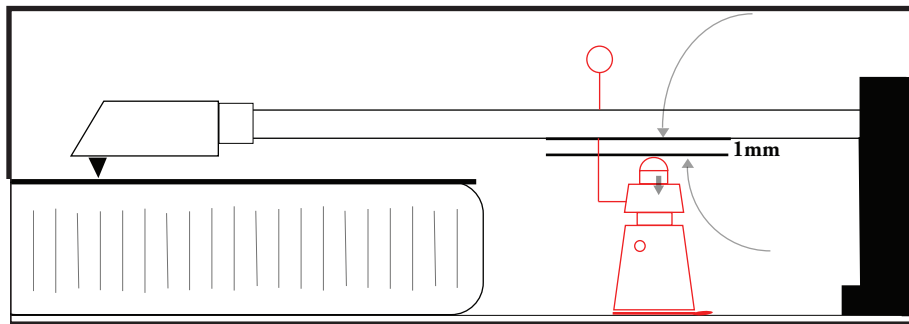

MOUNT METAL DISC

Keep protective cover on adhesive surface until final placement is determined.

F. In its up-position, swing the tonearm inwards until the stylus hovers over the run-out area - approx. 13mm (0.5") from the outer edge of the records paper label.

G. The adhesive on the metal mounting disc is pretty strong, so make sure you lay it down in the right position. It can be pried up with a thin blade, but laying it down loosely at first can be a good idea to lower the chance of damaging the plinth surface, if it needs repositioning. Separate the metal disc from Little Fwends magnet base.

H. Looking straight from above, take a mental note of where to place it. We recommend adhering it centered straight under the armtube, halfway between the platters edge and the tonearms pivot point. Remove the protective cover from adhesive side and mount the disc.

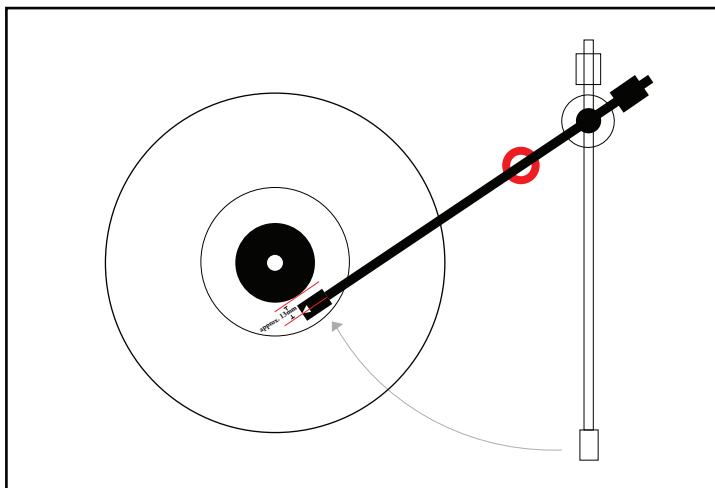

POSITIONING LITTLE FWEND

This is not an exact science, Little Fwend is designed to be reoriented for various run-out grooves, just by rotating or sliding it to desired position. As a general rule, the release mechanism works the smoothest if the release antenna runs parallel to the armtube at the point of contact for release.

I. Place tonearm in resting position.

J. Beware of the magnetic pull. Place Little Fwend on the metal disc.

K. Rotate Little Fwend so the release antenna sticks out towards 12 o'clock.

L. Hold the base steady with one hand and gently rotate rubber beam to 9 o'clock.

M. Swing tonearm in so the stylus hovers over the point you want the lifting mechanism to release.

N. Rotate Little Fwend counter-clockwise until antenna almost touches the armtube.

O. Gently push rubber beam down to the loaded position.

P. Lower the stylus at the lead-in groove and listen to music, fall asleep or walk the cat. Little Fwend is now ready for duty and will safely lift the tonearm when you are not. Remember to load Little Fwend before playing the next record.

